



AirScape™

1.0 WHOLE HOUSE FAN

INSTALLATION AND OPERATION GUIDE

CONGRATULATIONS on your purchase of the Airscape 1.0 Whole House Fan. This fan is designed to provide you with quiet, economical cooling for many years.

Please take a few minutes to read over the sections below to make sure you are prepared for the installation. The building owner/occupant should read the section "Where to Locate" below so that the 1.0 WHF will be correctly located to maximize usefulness and economy of operation.

If you (or your installer) have any questions regarding the installation, operation, or maintenance, please call your supplier or retailer who has the experience and training to assist you.

WHAT'S IN THE BOX

Prior to beginning installation, please verify that you received all the accessories with the whole house fan. The package should include:

- fan assembly
- grille (including attachment screws)
- dual speed switch and plate
- roll of adhesive backed foam tape
- wood screws to attach fan assembly
- installation instructions

WHERE TO LOCATE

Let's start with a little theory of operation: As your house heats up during the summer day, a large amount of heat is retained in the building structure. Even though many summer evenings offer very comfortable outdoor conditions, we are forced to either endure the hot conditions of our houses, or turn on the air conditioning and subject ourselves to the expense and possibly unhealthy air conditions.

The solution to this problem is certainly not new. Traditional, naturally ventilated, house designs and whole house fans have been around for a long time and offer some solution to this problem.

The better comfort solution, the 1.0 WHF, has been designed to run quietly and efficiently all night long. Building materials give up their heat slowly (touch the brick on your house after sunset) and this method of slow cooling extracts as much heat as possible from your house structure. Since the 1.0 WHF is one of the quietest whole house fans on the market, it also allows you to get a good night's sleep.

The diagram below (figure 2) illustrates how cool air enters an open window and replaces hot air that is exhausted by the 1.0 WHF into the attic. This dual action cools the interior of the house as well as the attic. Even if you have air conditioning, you can benefit by eliminating or minimizing the use of AC in the evening as well as pre-cooling the building structure, again helping to save on utility bills the next day.

FIGURE 1

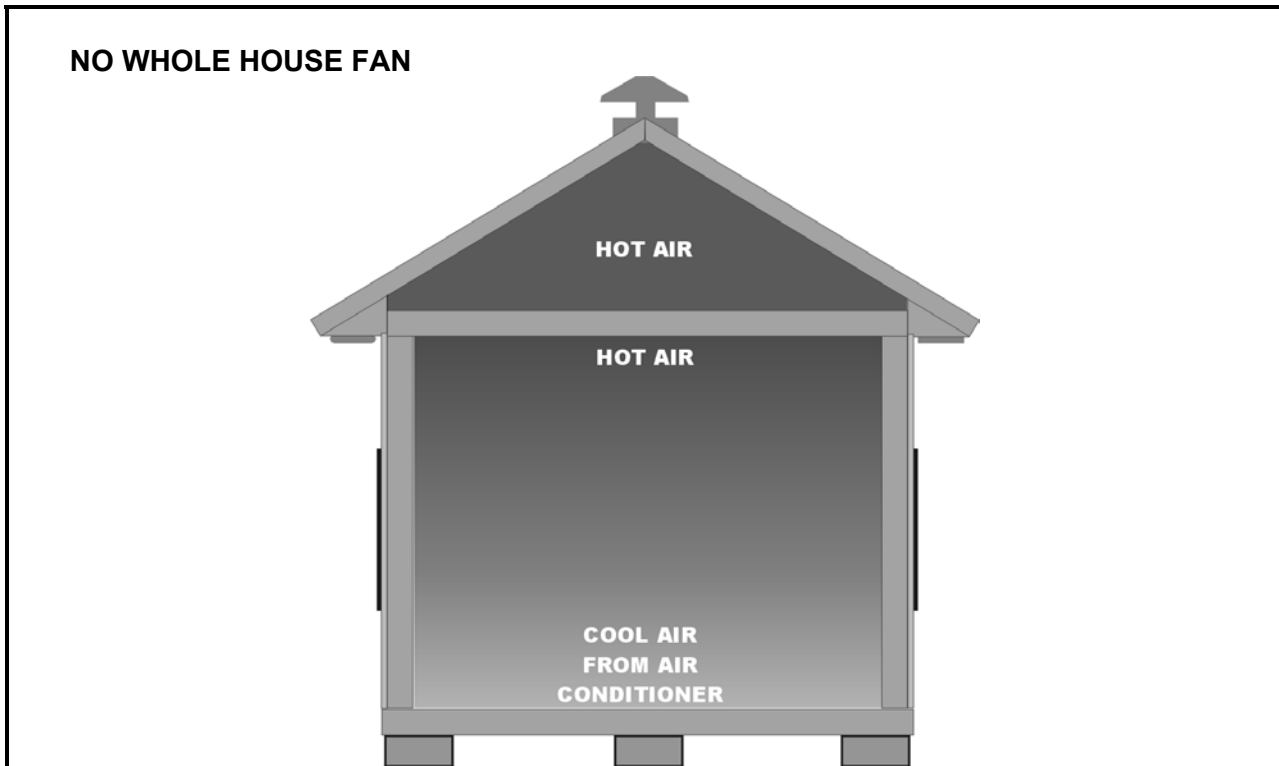
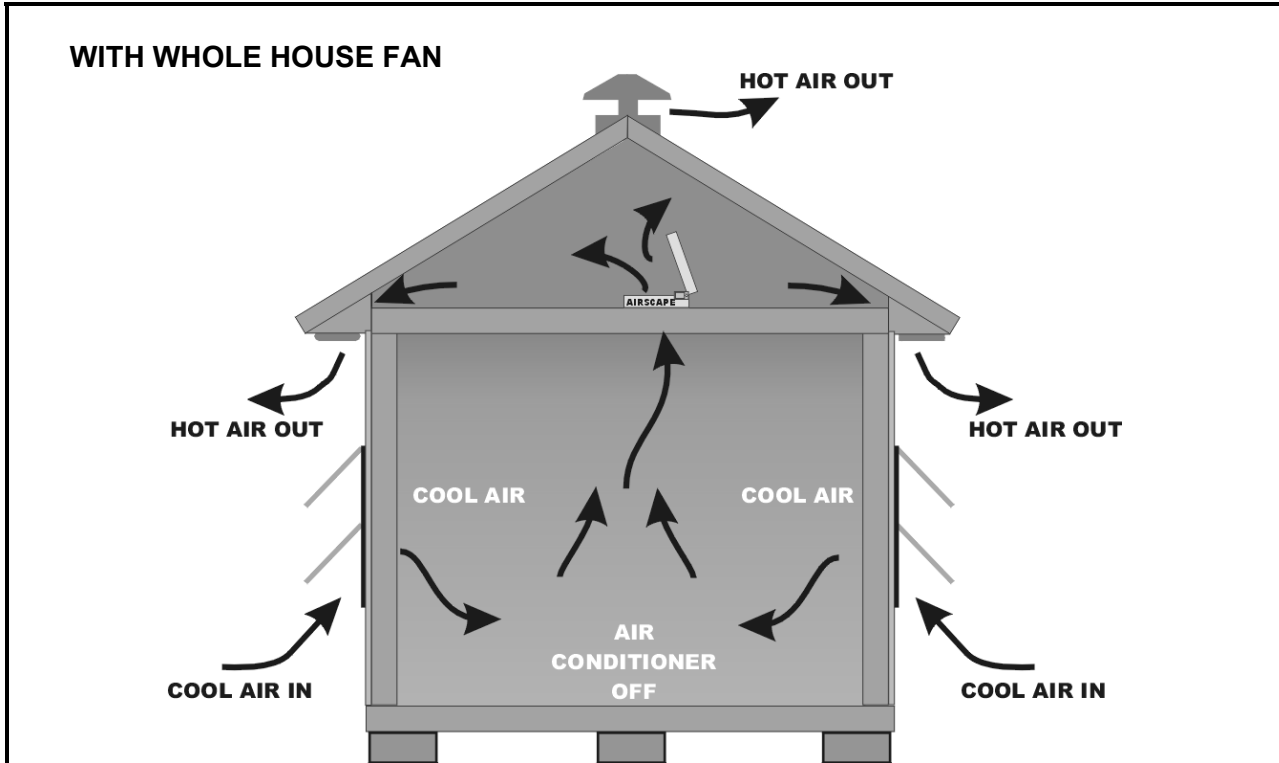

FIGURE 2



Ceiling or Wall?

The 1.0 WHF can be mounted in the horizontal or vertical orientation. Our recommended location is on a ceiling in the horizontal orientation -- keep in mind that it makes sense to place the unit high to eliminate the hottest air.

Acoustics:

Even though the 1.0 WHF is extremely quiet, we don't recommend installing the fan in a bedroom, since our perception of noise is far greater when the house is quiet. Hallways may be convenient, but the fan may "sound" noisier because of acoustic "reflections" from hard surfaces such as plaster. Generally, it is recommended to place the fan not in direct line of sight from a bedroom or other acoustically sensitive location.

We recommend placing the 1.0 WHF in a central location. Because halls are relatively large "ducts" the 1.0 WHF can be placed virtually anywhere in your house.

UNIT DIMENSIONS

FIGURE 3 – Dimensions.

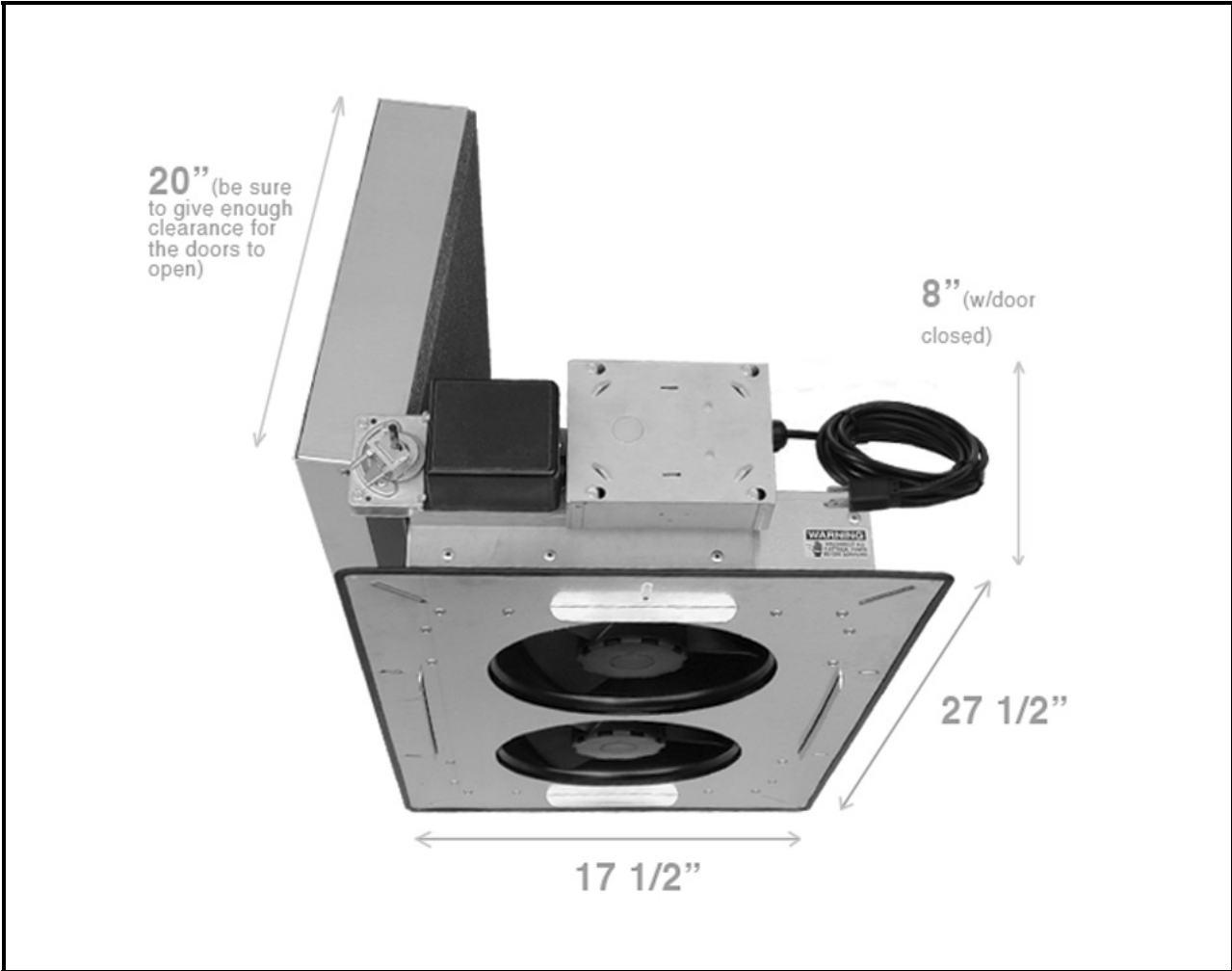

REQUIRED VENTING AREA

We recommend that your attic has 2 square feet of "net free" venting area. First of all let's define net free area. This is the area of an unobstructed opening that would be equivalent in terms of airflow to the louver or grille, etc. For example a 24" x 24" louver, with an area of 4 square feet, would have a net free area of 2 square feet (this is for a particular brand of louver, but the 50% ratio of net to actual is common).

You can obtain net free area numbers from each manufacturer, but here is a handy table that errs on the side of caution.

Example Item	Length (inches)	Width (inches)	Fraction Net Free Area	Net Free Area (square feet)
	L	W	FNA	= L x W x FNA / 144
Louver	16	16	0.5	= 16 x 16 x 0.5 /144 = 0.89
Ridge Vent	48	not used	0.13	= 48 x 0.13 /12 = 0.52
Eave Vent	12	4	0.5	= 12 x 4 x 0.5 /144 = 0.16

In practice, less net free area will decrease the airflow performance of the unit.

INSTALLATION - CARPENTRY

The 1.0 WHF has been designed to fit into a 14½" x 22½" wall or ceiling opening. Since most modern houses have been built with either 16" or 24" on-center (O.C.) spaced joists or studs, a simple "box" is constructed in the wall/ceiling.

The illustrations below (Figures 4 and 5) show the fan sitting on top of 2"x8" joists. The joists are 16" on-center and have a net space between them of 14½". Two 2x8's (to match existing 2x8" joists), 14½" long have been nailed in place to form the box. If your joists or trusses use 2" x "another depth", please substitute the appropriate depth pieces. Its good practice to seal (caulking sealant) the inside of the formed box to ensure that all air drawn in by the unit will be from inside the house.

Use a stud finder to locate the studs from below or drill pilot holes from above to outline the grille opening in the drywall ceiling. Cut the opening with a drywall cutter. The opening should be 14½" x 22½".

Place the included gasketing over the top of the joists, position the 1.0 WHF on top of the joists, and attach the unit with the wood screws (included). Do not over tighten the screws, since this may reduce the vibration isolation qualities of the gasketing.

The last step is to attach the interior grille to the joist with the included wood screws.

Be sure to allow adequate space around the unit to allow the door to open fully. See figure 6.

FIGURE 4 – Framing.

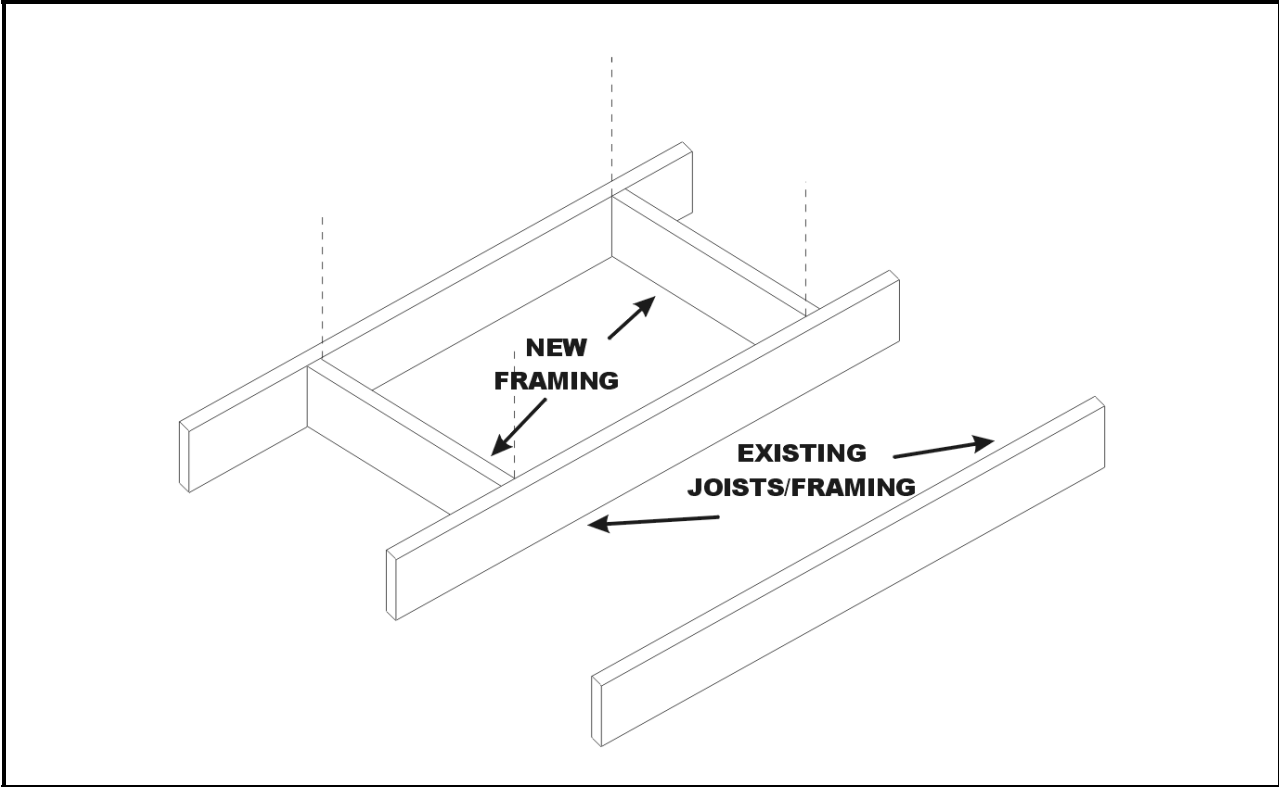

FIGURE 5 – Installed top (attic) view.

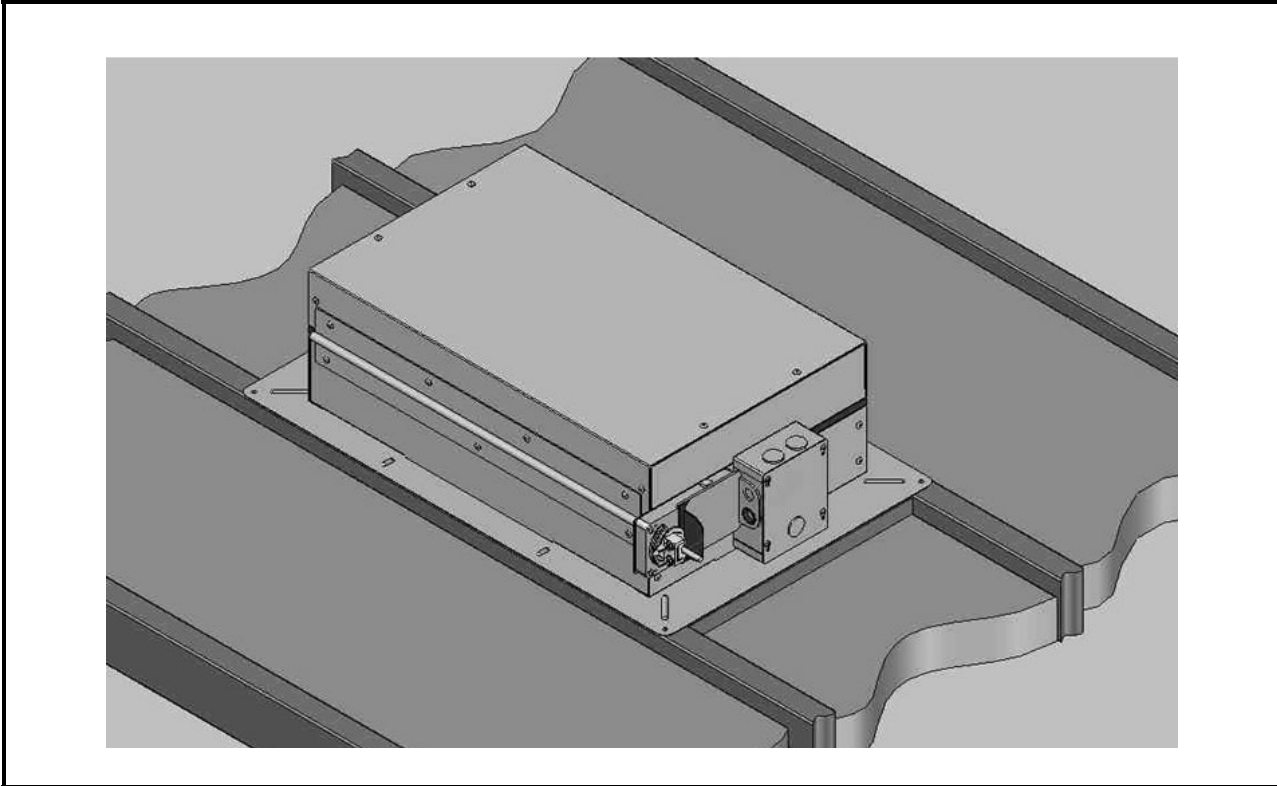
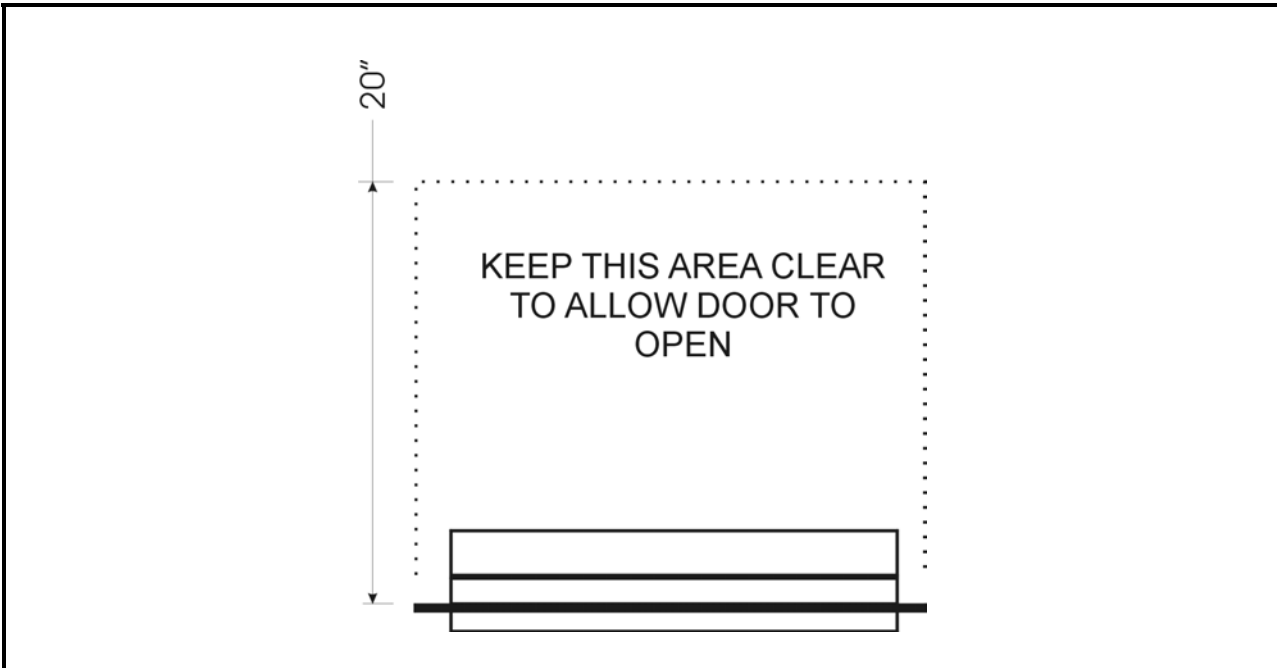

FIGURE 6 – Door Clearance.



INSTALLATION – WIRING (HARDWIRED SWITCH)

The easiest way to wire the 1.0 WHF is as follows (see Figure 7).

Step 1: Run a 3-wire cable for the 24 VDC low-voltage wiring from the unit to the wall-mounted double switch (included). Connect the control wiring to the switch and unit circuit board as shown in figure 7 below.

Step 2: When ready, plug-in the power cord into a 120-volt outlet. Alternatively, if you want to hardwire the unit, remove the power cord and provide 120-volt power to the unit mounted control/junction box. Connect power to the circuit board inside the control box (see figure 8).

The control wall switch must be mounted in an approved electrical box large enough to accommodate the entering wires. Use approved methods such as wire nuts to connect wire ends.

General wiring notes:

- Local codes and standards must be followed in the installation of this unit.
- A dedicated circuit for this unit is not required, however the power requirement of 120 volts, 1 amp must be taken into account when allocating power from existing electrical circuits.

FIGURE 7 – Wiring with hardwired switch and power cord.

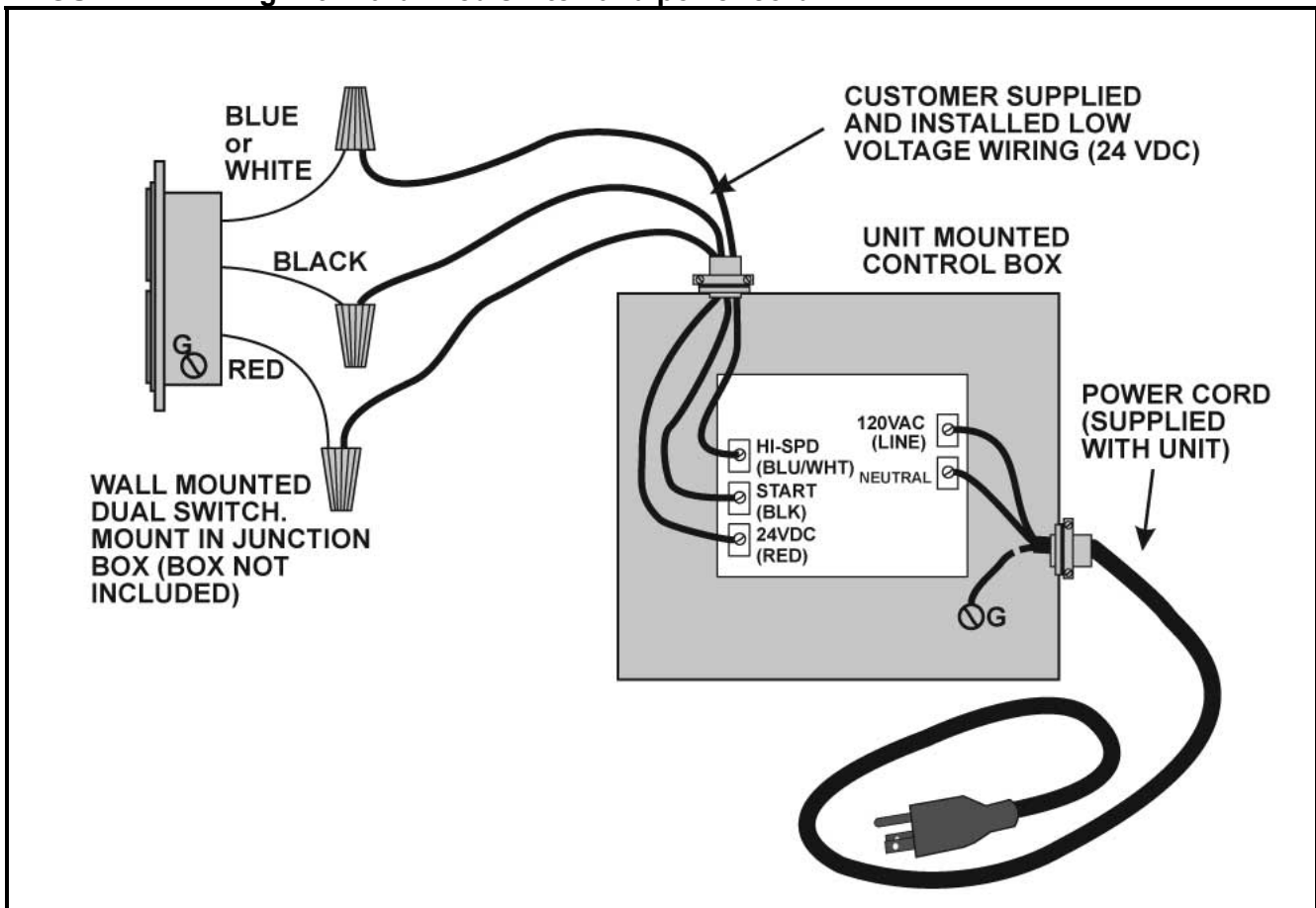
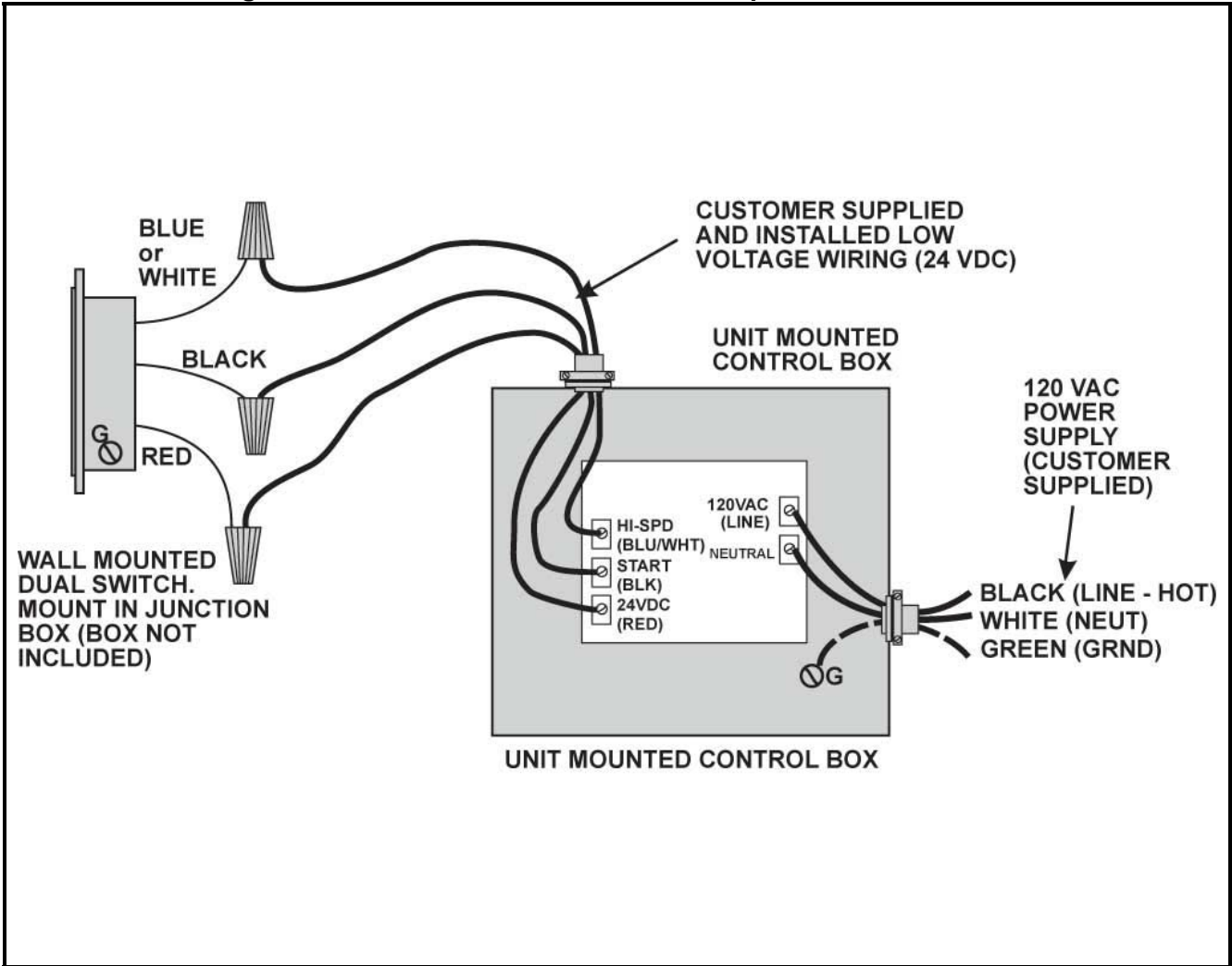

FIGURE 8 – Wiring with hardwired switch and hardwired power.



INSTALLATION – WIRING (OPTIONAL REMOTE CONTROL)

Figure 9 below shows wiring for the optional wireless remote control unit (not included).

Step 1: Remove the faceplate from the WHF electrical box. Remove the electrical knockout on faceplate and install the nylon insert. Route the black and white power wires that are on the back of the module through the nylon insert. Position the module onto the faceplate so that it is seated in between the mounting guides and pushed completely down onto the plate. Note that there will be a gap between the module and the faceplate. Install the module retaining bracket by sliding it down over the module (be careful not to damage wires), inserting bracket ends into small slots on electrical box faceplate. Make sure tabs on bracket snap completely into slots to lock module into place.

Step 2: Connect the 120-volt power wires (back of receiver) from the remote control receiver to the 120VAC(LINE) and NEUTRAL contacts on the circuit board as shown in figure 9.

Step 3: Connect the 24 VDC low-voltage wiring to the circuit board of the unit from the remote control receiver using a 3-wire cable as shown in figure 9.

Step 4: When ready, plug-in the power cord into a 120-volt outlet. Alternatively, if you want to hardwire the unit, remove the power cord and provide 120-volt power to the unit mounted control/junction box. Connect power to the circuit board inside the control box.

Step 5: See programming and security code information sheet included with the optional remote package for additional operation information.

General wiring notes:

- Local codes and standards must be followed in the installation of this unit.
- As noted in the diagram, use approved methods such as wire nuts to connect wire ends.
- A dedicated circuit for this unit is not required, however the power requirement of 120 volts, 1 amp must be taken into account when allocating power from existing electrical circuits.

FIGURE 9 – Wiring optional remote control unit – Power AND control wiring shown

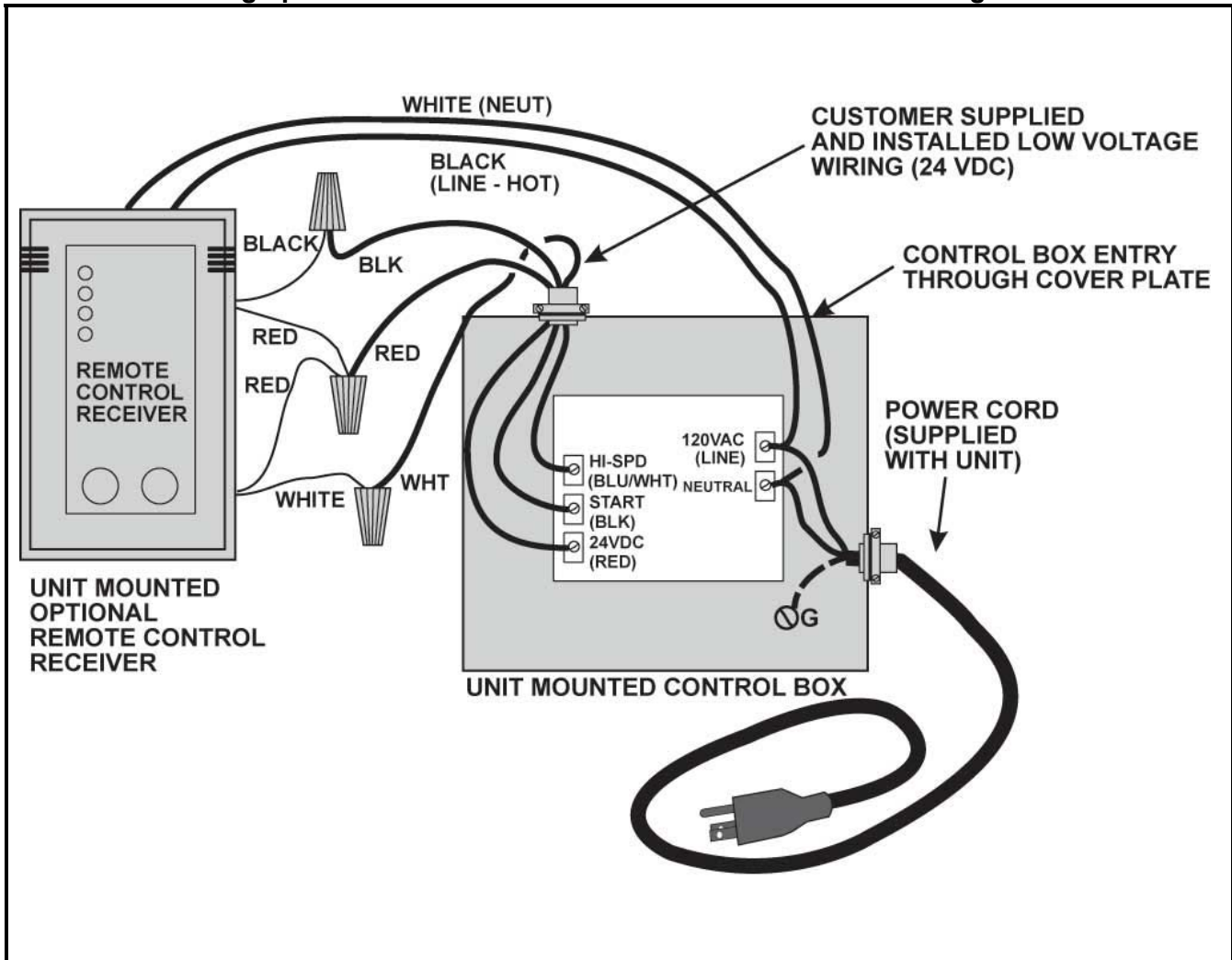

FIGURE 10 – Optional Remote Receiver Retaining Bracket.

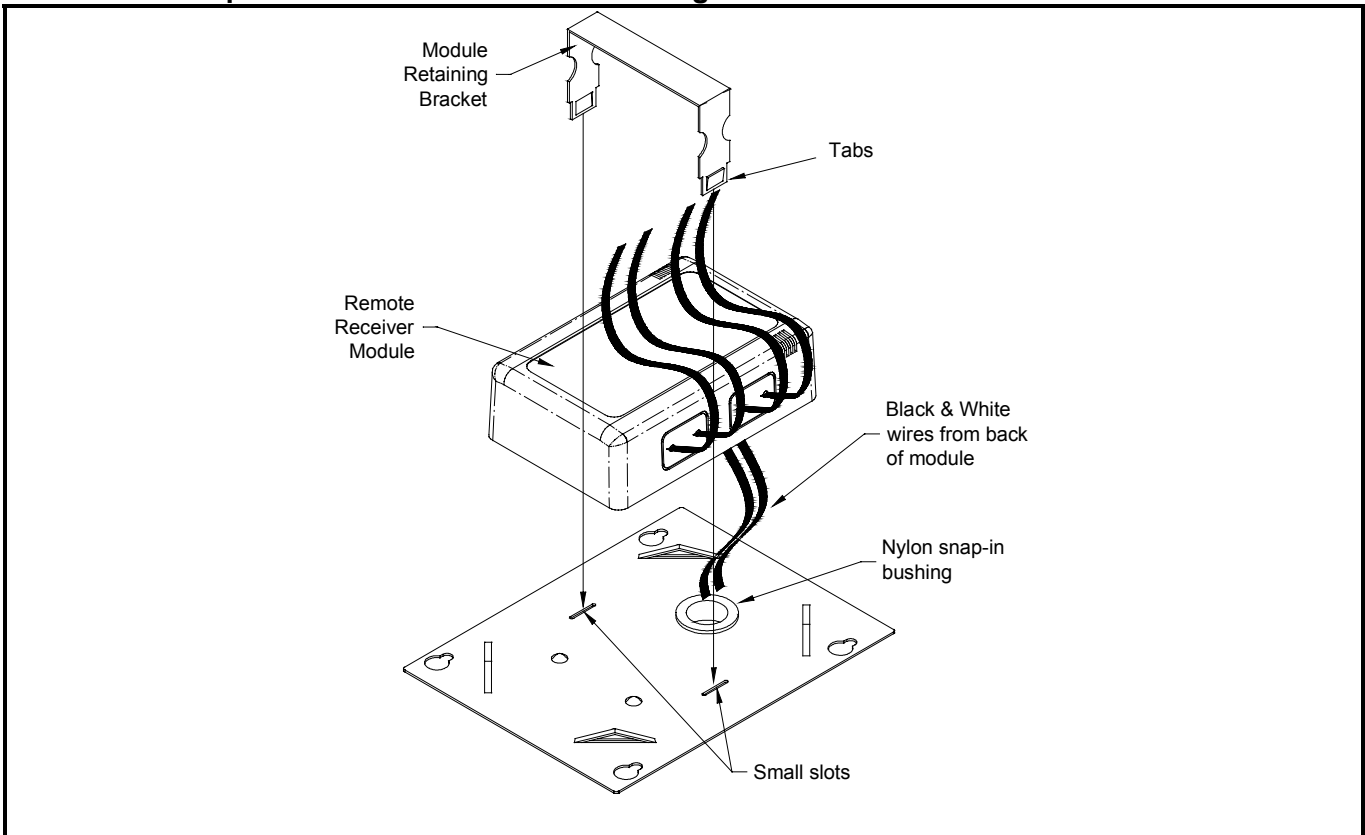

FIGURE 11 – Optional Remote Control Receiver.

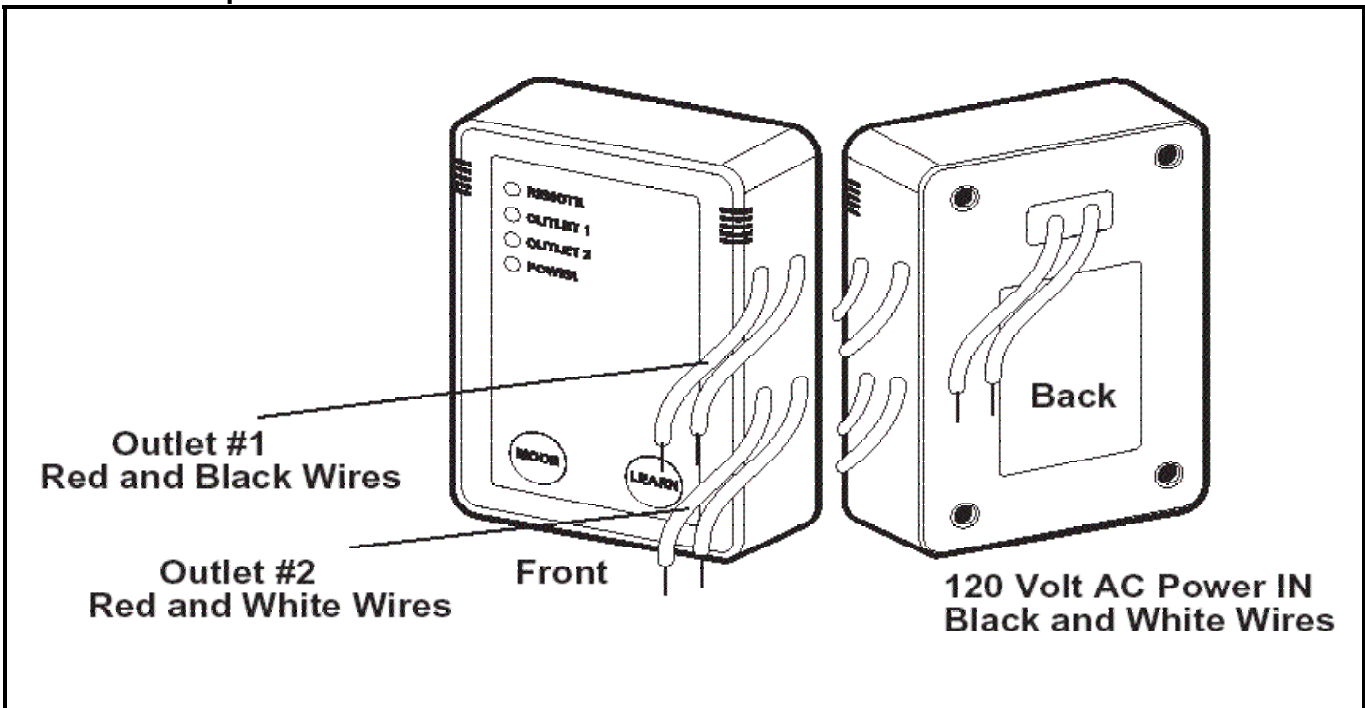
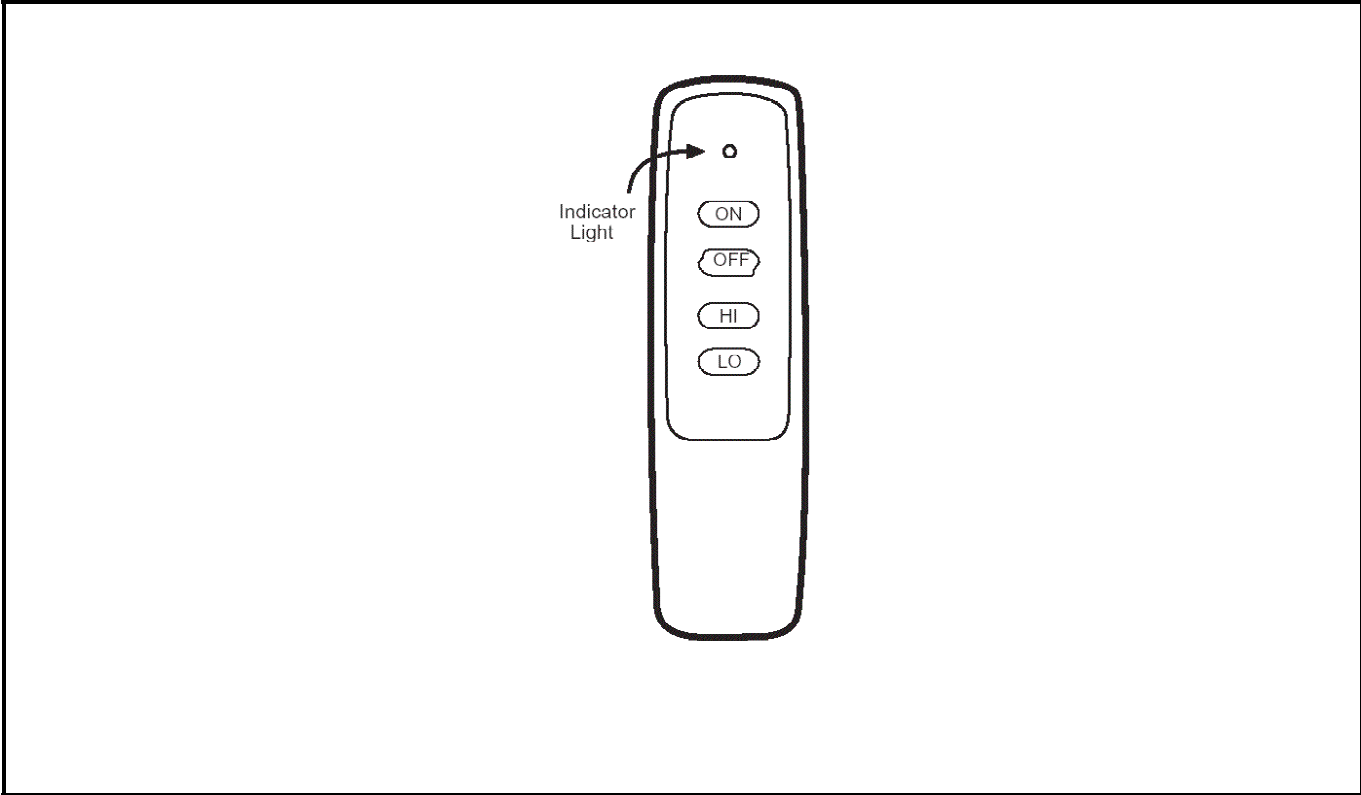

FIGURE 12 – Optional Remote Control Transmitter.



STARTUP AND OPERATION

- Make sure that all wiring and connections have been made per this manual and acceptable wiring standards.
- Make sure that no tools or construction debris have been left in or on the 1.0 WHF.
- Verify that the 1.0 WHF power switch is in the "off" position and turn on electrical power at the circuit breaker.
- Put the power switch to the "on" position, and toggle the fan speed switch, verifying that the unit runs in both high and low speed.
- When the power switch is moved to the "off" position, the fans should shut down and the damper doors begin to close. The doors will shut tightly within 60 to 90 seconds.

MAINTENANCE

There is no routine maintenance required for the 1.0 WHF other than to make sure that the fan blades and damper are kept clean of any possible build up of lint or other debris. Blocking the fan discharge during operation could cause premature fan failure if internal temperatures rise to a very high level. Ensure that no items are placed within 2 feet of the fan discharge path.

TROUBLESHOOTING

The 1.0 WHF has been factory tested. If you have problems with the unit please take a few minutes to run through the following troubleshooting procedures before calling your installer or retailer.

1) Symptom: Unit does not start

Possible causes: No power to unit.

Suggestion 1: Check power to the unit and wiring at both the switches and the unit mounted junction box.

Suggestion 2: If power is verified at the unit, remove all control wiring from the low voltage control side. Jumper 24VDC RED terminal to START (BLK). The fans should start and the damper door should open. When the jumper is removed the fans should stop and the damper should close. If the start/stop sequence checks out then there is an issue with field wiring to the switch or remote.

2) Symptom: Damper does not open

Possible causes: No power to damper actuator or damper shaft loose.

Suggestion: Check power to unit and wiring. The actuator (actuator mounted terminal block, not circuit board) should always have 120 V power to terminal 2 and 4, and terminal 3 only when fans running (open damper). Terminal 1 should be the 120 V neutral. Verify that the actuator jaws are closed tight on the damper shaft.

3) Symptom: One or more fans do not run

Possible causes: Wiring issue with fan or damaged fan.

Suggestion: Verify fan wiring connections at circuit board.

4) Symptom: Unit does not run on low speed

Possible causes: Wiring issue.

Suggestion: Verify wiring connections to the low/high speed selector.

- 5) Symptom: Unit does not run on high speed
Possible causes: Wiring issue.
Suggestion: Verify wiring connections to the low/high speed selector.

If you continue to have issues with the unit, or have questions about the installation and wiring, please contact the manufacturer or your local retailer.



Before servicing the unit, switch power off at the electrical panel to reduce the risk of electrical shock, fire, or injury.

SAFETY INFORMATION



Not so obvious - Please Read:

Do not operate the 1.0 WHF without a window or door open.

This fan is meant for general ventilation. It has **NOT** been designed to vent particle laden and/or explosive mixtures of air.

If people or pets are expected to be in proximity to an operating 1.0 WHF, there is risk of personal injury from the fan blades. If you feel this situation will occur, **DO NOT** operate the fan without a fan guard. Contact the manufacturer for more information on this subject.

LIMITED WARRANTY

HVACQuick.com (Distributor) warrants from the date of purchase that the product supplied by Distributor is free of defects in material and workmanship for a period of 3 years. This includes all moving parts, motors, dampers, and damper actuators.

If a failure of the product occurs, contact Distributor at 877-711-4822 and give the model number of the product, the purchase date, proof of purchase, and a description of the problem. The Distributor will cover shipping charges during the first 6 months of warranty. Customer is responsible for all inbound and outbound shipping charges after the initial 6 month period.

Once a problem is diagnosed, and proof of purchase is verified, the Distributor will have the option of shipping the necessary repair part(s) to the Customer or having the product returned to the Distributor for repair or replacement.

If the Distributor finds the returned product to be in operating condition, the product will be returned to the customer at customer's expense. Distributor reserves the right to obtain a credit card authorization for possible freight charges or non-return of defective parts/unit.

Specific warranty exclusions:

Except as provided by this express warranty, the goods are sold without any implied warranties.

This limited warranty does not cover labour or field diagnosis, nor does it cover failure of the installer to follow installation instructions, damage resulting from accident, misuse or abuse, lack of maintenance, improper installation.

In no event, shall the Distributor be liable for any special, incidental, or consequential damages resulting from any defect in material or workmanship. It is expressly understood that Buyer's sole and exclusive remedy shall be repair or replacement of defective parts.

UNIT SPECIFICATIONS

Unit Weight:	26 lbs
Rough Opening:	14.5"x22.5"
Grille Outer Dimensions:	15.75"x25.75" (stamped metal)
Grille:	Standard: Metal stamped grille - painted white Optional: Aluminum with cube core center - powder coated white
Electrical:	115 VAC, 60 Hz
Energy Consumption:	70 watts total (2 fans)
Speeds:	2
Airflow - High Speed:	1000 CFM
Airflow - Low Speed:	600 CFM
Acoustical - High Speed:	3 Sones
Acoustical - Low Speed:	2 Sones
Installation:	Installs easily between either 16" or 24" O/C joists
Operation:	Standard: Dual SPST switch (Decora style) Optional: Remote control
Insulation:	Insulated damper: True R-22 (3" of insulation)
Warranty:	3 years